

CAD FILE:

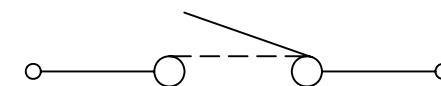

SCHEMATIC

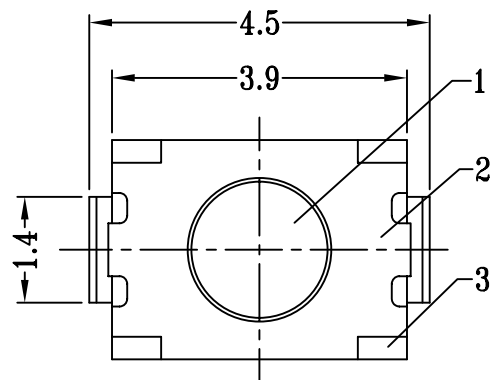
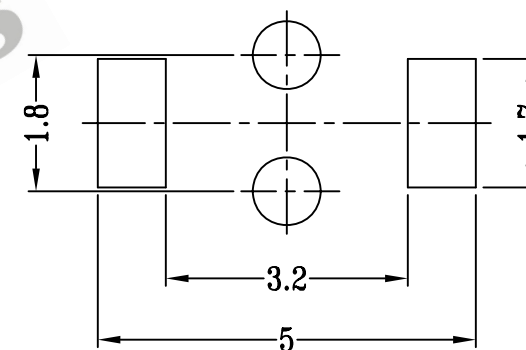
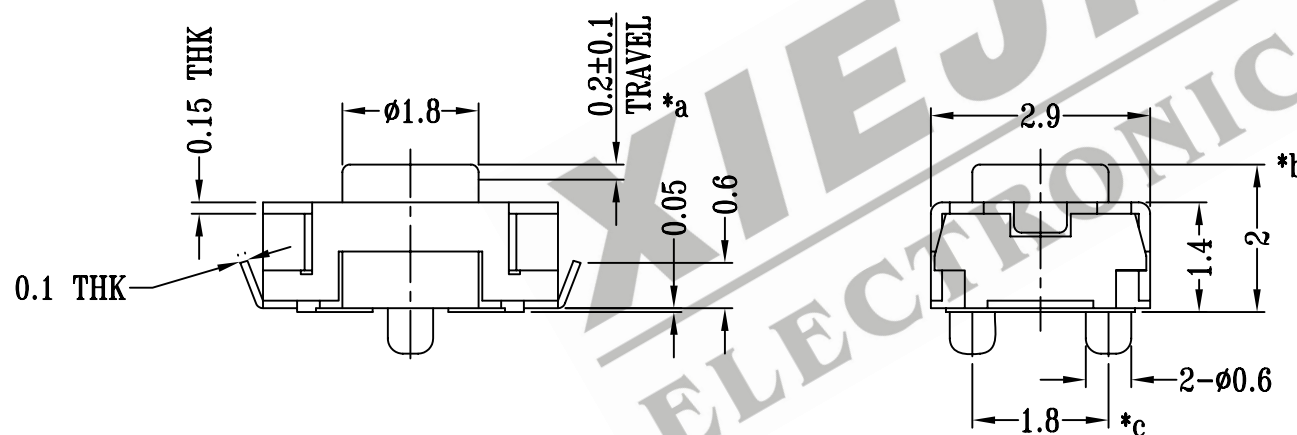

P.C.B LAYOUT

注：“*”表示关键尺寸（3个）

NO.	PARTS	MATERIALS	Q'TY	FINISH	TOLERANCE UNLESS SPECIFIED	SHENZHEN XIEJIA ELECTRONICS CO.,LTD.				
8					WITHIN: 1.5±0.1mm	ISSUE	DATE	DESCRIPTIONS OF REVISION		APPD.
7				OVER: 1.5±0.2mm						
5	SEAL PLATE	PET	1	CLEAR	TITLE : TACT SWITCH		UNIT : mm	DRWG NO.: XJ-DR-TD85EU-00		
4	CONTACT	SUS	2	Ag CLAD	MODEL: TD-85EU		SCALE: 10:1	DWN.	ZHOUYU	2006-6-10
3	CASE	NYLON46/BRASS STRIP	1	BLACK/Ag PLATED OVER Ni PLATED	ALL MATERIALS MUST BE COMPLIANT TO ROHS			CHK'D	FANGYING	2006-6-10
2	COVER	0.15mm SUS	1	WASHING				APPD.	KANGXINAN	2006-6-10
1	KNOB	NYLON+F.G+94VO	1	BLACK						